

Hand pallet truck 2.0 ton

BT lifter

L-series

LHM200SC



Hand pallet truck

| Truck specifications | | | | | LHM200SC |
|----------------------|----------------|--|--------------------------------|--------------------|-----------------------------|
| Identification | 1.1 | Manufacturer | | | Toyota |
| | 1.2 | Manufacturer's type designation | | | LHM200SC |
| | 1.4 | Operator type | | | Hand |
| | 1.5 | Load capacity/rated load | Q(t) | kg | 2000 |
| | 1.6 | Load centre distance | c | mm | 600 |
| | 1.8 | Load distance, centre of drive axle to fork | x | mm | 945 ¹⁾ |
| | 1.9 | Wheelbase | y | mm | 1170 ¹⁾ |
| Weight | 2.1 | Service weight | | kg | 103 |
| | 2.2 | Axle load, with load, drive/castor/fork wheel | | kg | 375/805 |
| | 2.3 | Axle load, without load, drive/castor/fork wheel | | kg | 20/10 |
| Wheels | 3.1 | Steer/fork wheels: Powerthane (Po), Steel (S), Nylon (N), Polyurethane (P), Rubber (R), Rubber antistatic (Ra) | | | N, P, S, Po, R, Ra/N, P, Po |
| | 3.2 | Wheel size, front | | | 175x60 |
| | 3.3 | Wheel size, rear | | | 85x100/85x75 ²⁾ |
| | 3.5 | Wheels, number front/rear (x = driven wheels) | | | 2/2 or 2/4 ²⁾ |
| | 3.6 | Track width, front | b ₁₀ | mm | 132 |
| | 3.7 | Track width, rear | b ₁₁ | mm | 370/530 |
| Dimensions | 4.4 | Lift | h ₃ | mm | 115 |
| | | Lift height | h ₂₃ | mm | 205 |
| | 4.9 | Height of tiller in drive position, min./max. | h ₁₄ | mm | 1220 |
| | 4.15 | Height, lowered | h ₁₃ | mm | 90 |
| | 4.19 | Overall length | l ₁ | mm | 1520 |
| | 4.20 | Length to face of forks | l ₂ | mm | 370 |
| | 4.21 | Overall width | b ₁ /b ₂ | mm | 540/700 ³⁾ |
| | 4.22 | Fork dimensions | s/e/l | mm | 65/170/1150 |
| | 4.25 | Width over forks | b ₅ | mm | 540/700 ³⁾ |
| | 4.32 | Ground clearance, centre of wheelbase | m ₂ | mm | 25 |
| | 4.33 | Aisle width for pallets 1000x1200 crossways | A _{st} | mm | 1525 ¹⁾ |
| | 4.34 | Aisle width for pallets 800x1200 lengthways | A _{st} | mm | 1725 ¹⁾ |
| 4.35 | Turning radius | W _a | mm | 1370 ¹⁾ | |

1) Distance with forks raised.

2) Single wheel/Boggie wheel.

3) Other widths available on request.

| | | | | |
|------------|------------------------------------|---------------|----|-----|
| Scale data | Graduation multi-range | | | |
| | 0 - 200 | | kg | 0,2 |
| | 200 - 500 | | kg | 0,5 |
| | 500 - 2000 | | kg | 1,0 |
| | Maximum inaccuracy, applied weight | | kg | 0,1 |
| | Battery | 12 Vdc/1,2 Ah | | |
| | Charger | 230 V/12 Vdc | | |

All data are based on table configuration. Other configurations may give other values.

Truck performance and dimensions are nominal and subject to tolerances.

Toyota Material Handling products and specifications are subject to change without notice.

Dimensional drawings

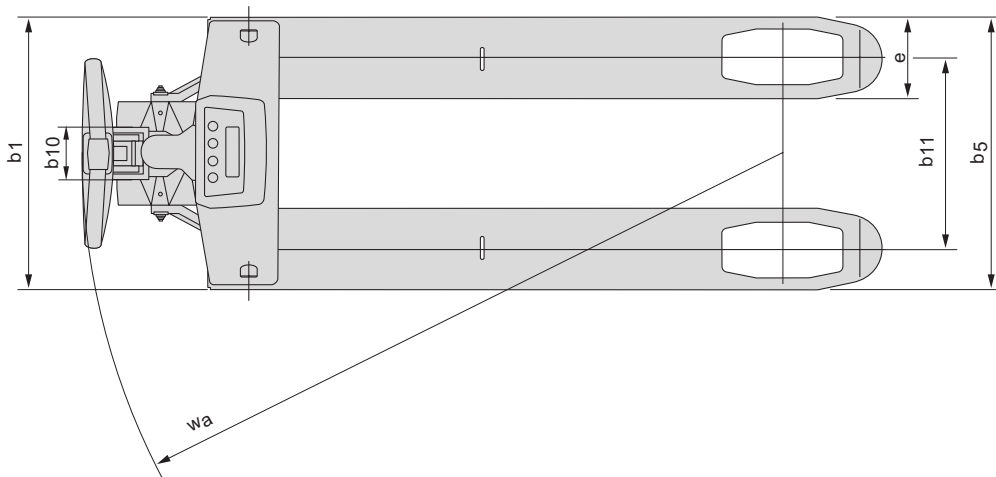
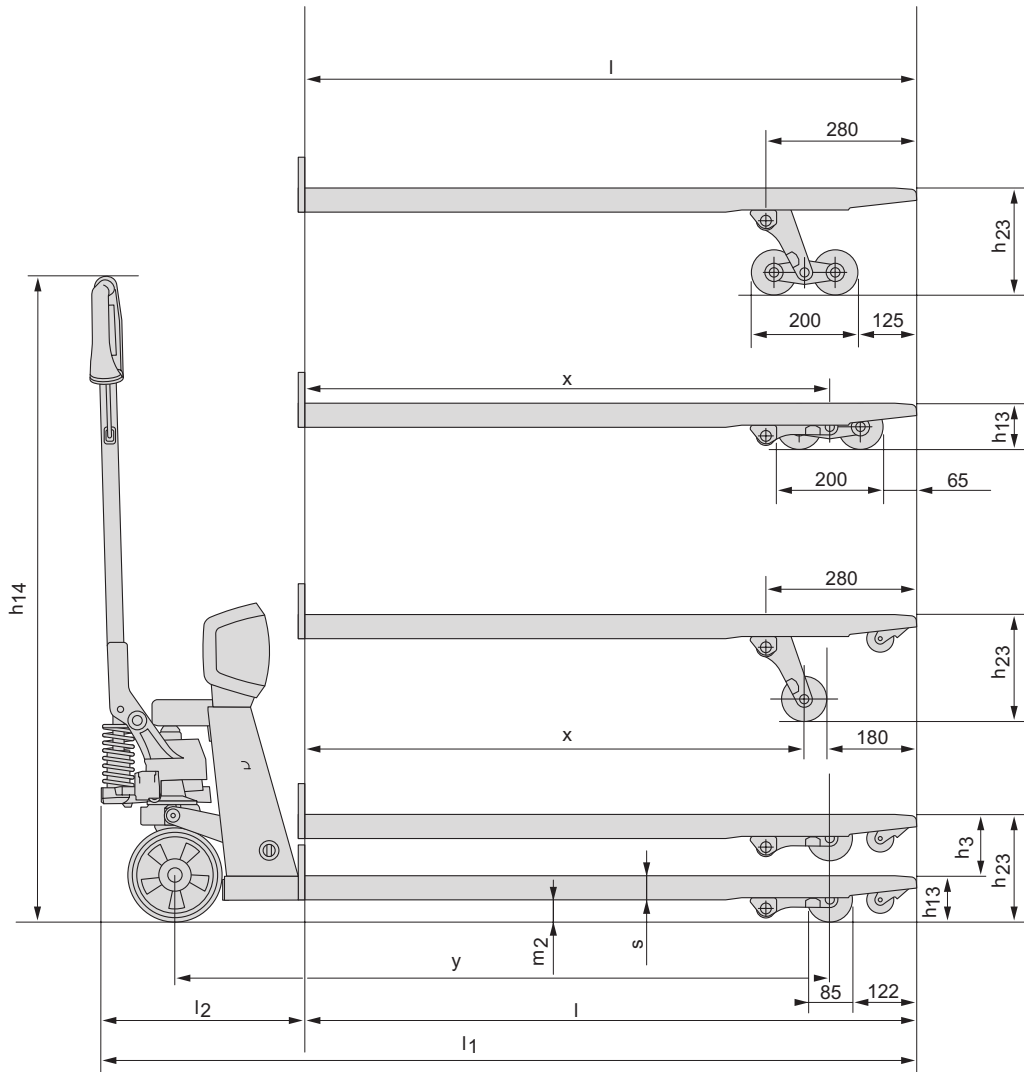

Truck features:

- The BT Lifter with scale – a mobile high precision weighing truck.
- The BT Lifter with scale is developed for industrial applications and is protected against water, dust and shocks.
- The exchangeable battery module provides for 35 hours of use, plus makes it possible to use the hand pallet truck without weighing when charging the battery.
- Legal for trade version available on request.
- Built in printer for printing weight data on site is available on request.
- Greasable bushings ensure a long service life.
- Angled high strength polymer handle for best ergonomic grip.
- This product has been environmentally declared.



TMHI-Toyota Material Handling Int. — 745347-040, version 3, 2018-11-02