

Hand pallet truck 1.0 tonne

BT pro lifter

LHT100

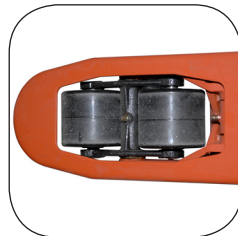
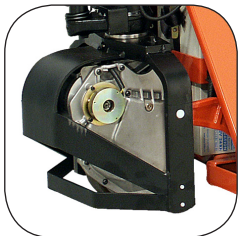

Hand pallet truck

Truck specifications					LHT100
Identification	1.1	Manufacturer			BT
	1.2	Manufacturer's type designation			LHT100
	1.3	Drive			Battery
	1.4	Operator type			Hand
	1.5	Load capacity/rated load	Q(t)	kg	1000
	1.6	Load centre distance	c	mm	600
	1.8	Load distance, centre of drive axle to fork	x	mm	945 ¹⁾
	1.9	Wheelbase	y	mm	1170 ¹⁾
Weight	2.1	Service weight including battery according to 6.5		kg	107
	2.2	Axle load, with load, drive/castor/fork wheel		kg	386/360
	2.3	Axle load, without load, drive/castor/fork wheel		kg	82/12
Wheels	3.1	Steer/fork wheels: Powerthane (Po), Steel (S), Nylon (N), Polyurethane (P), Rubber (R), Rubber antistatic (Ra)			P/Po, N, P
	3.2	Wheel size, front			175x50
	3.3	Wheel size, rear			85x100 / 85x75 ²⁾
	3.5	Wheels, number front/rear (x=driven wheels)			1/2 or 1/4 ²⁾
	3.6	Track width, front	b ₁₀	mm	520/685
	3.7	Track width, rear	b ₁₁	mm	364/529
Dimensions	4.4	Lift	h ₃	mm	115
		Lift height	h ₂₃	mm	200
	4.9	Height of tiller in drive position, min./max.	h ₁₄	mm	1220
	4.15	Height, lowered	h ₁₃	mm	85
	4.19	Overall length	l ₁	mm	1575
	4.20	Length to face of forks	l ₂	mm	415
	4.21	Overall width	b ₁ /b ₂	mm	520/685
	4.22	Fork dimensions	s/e/l	mm	45/156/1150 ³⁾
	4.25	Width over forks	b ₅	mm	520/685
	4.32	Ground clearance, centre of wheelbase	m ₂	mm	40
	4.33	Aisle width for pallets 1000 x 1200 crossways	A _{st}	mm	1525 ¹⁾
	4.34	Aisle width for pallets 800 x 1200 lengthways	A _{st}	mm	1725 ¹⁾
4.35	Turning radius	W _a	mm	1370 ¹⁾	
Performance	5.1	Travel speed, with/without load		km/h	3.5/5
	5.3	Lowering speed, with/without load		m/s	Controlable
	5.7	Gradeability, with/without load		%	—
	5.8	Max. gradeability with/without load		%	—
	5.10	Service brake			3.0 Nm
Electric motor	6.1	Drive motor rating S2 60 min		kW	0.2
	6.4	Battery voltage, nominal capacity K _s		V/Ah	2 x 12/24
	6.5	Battery weight		kg	2 x 9.5
Others	8.1	Type of drive control			Push button
	8.4	Sound level at the driver's ear according to DIN 12 053		dB(A)	63

1) Distance with forks raised

2) Single wheel / Bogie wheel

3) Other fork length available: 800/910/1000/1070/1220

All data are based on table configuration. Other configurations may give other values.

Truck performance and dimensions are nominal and subject to tolerances.

Specifications are subject to change without notice.

Dimensional drawings

BT lifter

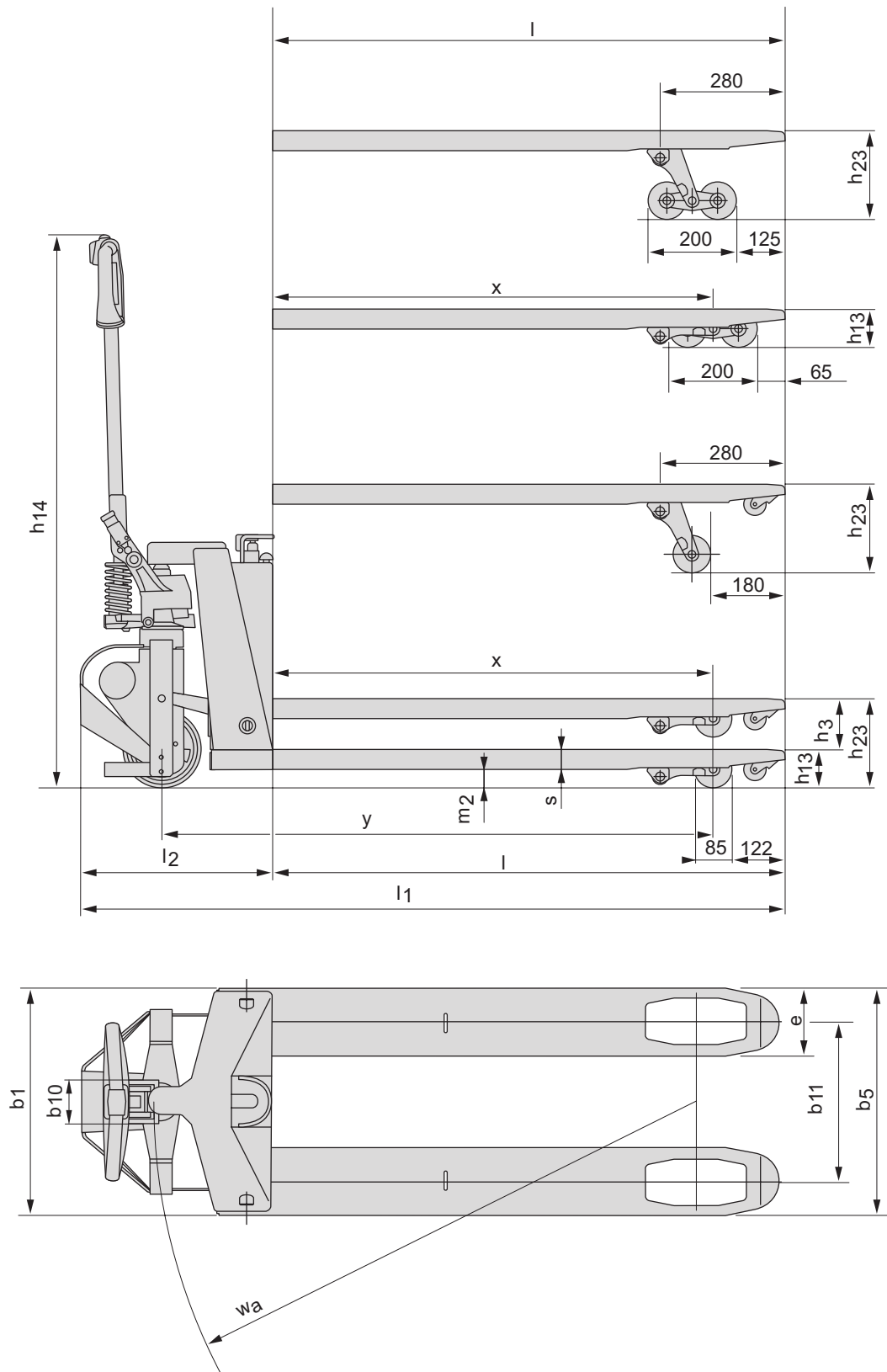

Truck features:

- The motorised hand pallet truck will eliminate the strain from pulling and pushing a hand truck. This 1000 kg capacity machine is another step towards an ergonomic workplace.
- Increased ergonomomy, no strain on arms, shoulder and back.
- Increased productivity – thanks to safety features.
- Suitable for multiple indoor applications.
- Safety features includes: emergency stop key, safety switch against collision and tow bar switch for the two end positions of the tow bar.
- Built-in charger with a separate charging cable.
- Also available in low fork height (U-model) with minimum height 75 mm.
- This product has been environmentally declared.



TP-Technical Publications — 745346 - 0411